

ANNEX 'A'

STRIKE

**5A**

**FUSIBLE LINK STRIKE**  
#14: MODEL '6'

AUTOMATICALLY ALLOWS THE COVER TO OPEN WHEN TEMPERATURE REACH 165°F (74°C)

\* CAN'T BE CONNECTED TO AN ALARM SYSTEM.\*

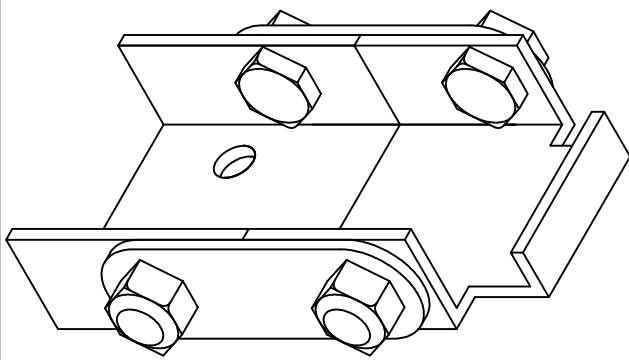

**5B**

**ELECTROMAGNETIC STRIKE**  
#15: MODEL 'CX-915-06TLS'

ELECTROMAGNETIC LOCK STRIKE AVAILABLE IN 24 OR 12 VOLTS AC/DC COULD BE CONNECTED TO THE ALARM SYSTEM. PROVIDE ROOF HATCH DOOR OPENING WHEN THERE IS DETECTION OF SMOKE, FIRE, EXCESSIVE HEAT OR GAS DEPEND ON THE ALARM SYSTEM OF YOUR PROJECT

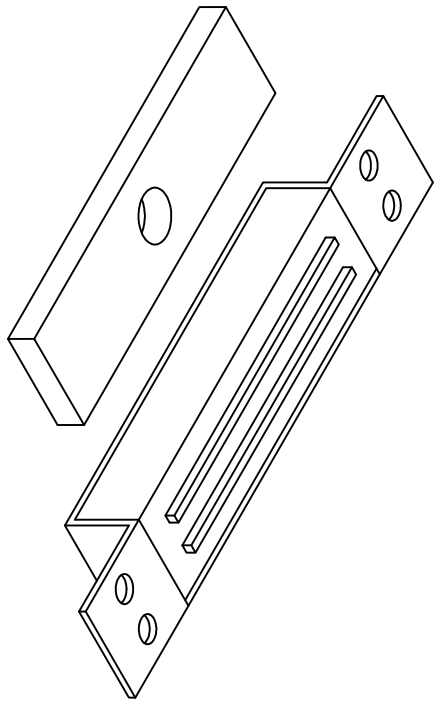

PROJECT

**BOLAR** 50, OMER DE SERRES,  
BLAINVILLE, QUÉBEC,  
CANADA, J7C 5H2  
PHONE:(450) 435-7385 ---- FAX:(450) 435-3600  
http://www.bolar.com  
webmaster@bolar.com

DISTRIBUTOR:  
ARCHITECT:  
CONTRACTOR:

DATE	No. ORDER	No. DWG